

12ICS100

ICS series Intensive Cycle Service

Narada's ICS series battery designed to provide high cycling and fast charge performance, idea for telecom service where power supply is unstable. With innovative structure design, high quality manufacturing and high quality material, ICS batteries are also capable of PSoC, hybrid, renewable energy storage application and other cycling/standby applications.

ICS series also have true front access terminal and front-access gas collection tubing for fast installation and facilitates maintenance.



Features & Benefits

- Extra high cycling and fast charge performance
- Designed for intensive cycle service where unstable grid power supply or no-grid, such as Telecom BTS, hybrid genset, renewable energy storage application
- Suit for 19" or 23" and ETSI power racks/cabinets with front terminal
- Superb security and reliability, more cost effective than nearest equivalent
- 12 years design float life at 25°C
- Wide operating temperature range -40°C to +50 °C
- True front-terminal design
 - Not requiring any additional space between the top of the battery and the next shelf
 - Easy paralleling of 48V strings (on 2 or more shelves) or 2x24V strings on one shelf via cost-effective flexible cables running along front surface
 - With rotational symmetry not requiring expensive and long cables when long strings are assembled on multiple
- Easy installation and verification of gas collection tubing via twin front-access gas nipples also with easy connection over several shelves
- Fold-away handles for easy installation and removal from shelves

Drawings

12V monobloc dimensions (in mm)

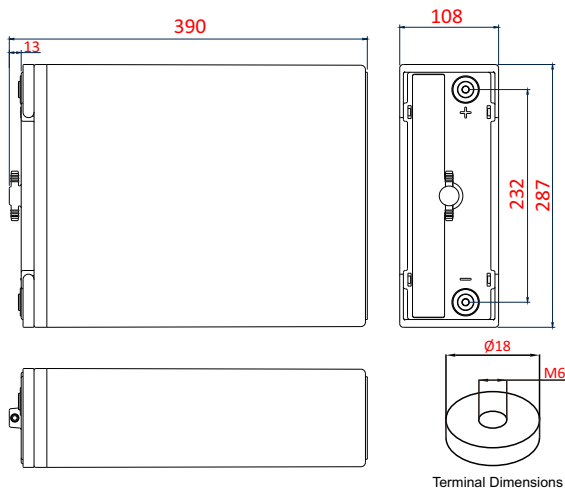

48V system: Total installation depth 390mm, including connector, bolt, insulation protective cover.

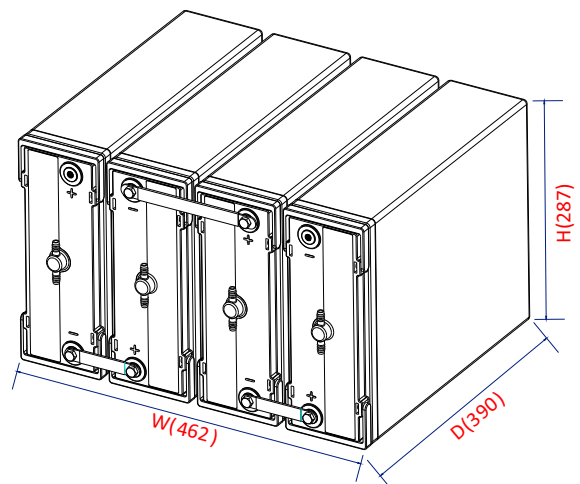

12ICS100

ICS series Intensive Cycle Service

Technical specifications

Electrical data

Nominal voltage	12 V
Number of cells	6
Rated capacity(25°C)	100 Ah - 10A for 10h to 1.80V/cell
Float voltage	2.25Vpc at 25 °C
Cycle and equalize charge voltage	2.35Vpc at 25 °C
Internal resistance	6.15 mΩ (acc. to IEC 60896-21)
Short circuit current	2150 A (acc. to IEC60896-21)
Max. charge current	Unlimited, otherwise 25A max. if T>25°C
Self discharge	The residual capacity is above 94% after 90 days storage(25°C/77°F)

Mechanical data

Weight ready for use	35 kg (77.2 lbs)
Length	390 mm (15.4 in)
Width	108 mm (4.25 in)
Height of monobloc	287 mm (11.3 in)
Total height	287 mm (11.3 in)
Terminal	M6 female
Terminal hardware torque	8±1.0 Nm

Constant Current Discharge Characteristics Units: Amperes (25 °C, 77 °F)

End Voltage	1hr	2hr	3hr	4hr	5hr	6hr	8hr	10hr	12hr	20hr	24hr
1.60Vpc	71.2	42.4	30.4	23.8	19.6	16.6	12.9	10.5	8.73	5.35	4.48
1.65Vpc	70.8	42.1	30.3	23.7	19.5	16.5	12.8	10.4	8.71	5.34	4.47
1.70Vpc	70.0	41.8	30.0	23.5	19.3	16.3	12.6	10.2	8.68	5.32	4.45
1.75Vpc	68.5	41.0	29.5	23.2	19.1	16.2	12.5	10.1	8.57	5.26	4.41
1.80Vpc	65.9	39.7	28.7	22.6	18.6	15.9	12.3	10.0	8.44	5.20	4.36

Constant Power Discharge Data Units: Watts per cell (25 °C, 77 °F)

End Voltage	1hr	2hr	3hr	4hr	5hr	6hr	8hr	10hr	12hr	20hr	24hr
1.60Vpc	133	79.2	57.5	45.3	37.5	32.2	24.9	20.5	17.3	10.9	8.94
1.65Vpc	132	79.0	57.4	45.2	37.4	32.1	24.8	20.4	17.2	10.8	8.93
1.70Vpc	130	78.8	57.2	45.0	37.2	31.9	24.6	20.2	17.0	10.6	8.90
1.75Vpc	128	77.7	56.6	44.6	37.0	31.6	24.5	20.0	16.9	10.5	8.82
1.80Vpc	124	75.8	55.3	43.8	36.3	31.0	24.1	19.7	16.7	10.4	8.71

NARADA POWER SOURCE CO.,LTD.

Add: Building A, NO. 822 Wen'er West Road, Hangzhou, Zhejiang, China 310030

Tel: (+86-571) 56975980

E-mail: intl@narada.biz

Fax: (+86-571) 56975955

Website: en.naradapower.com

